

 **QUEST**
metal detectors

Q40





IN THE BOX

QUICK START

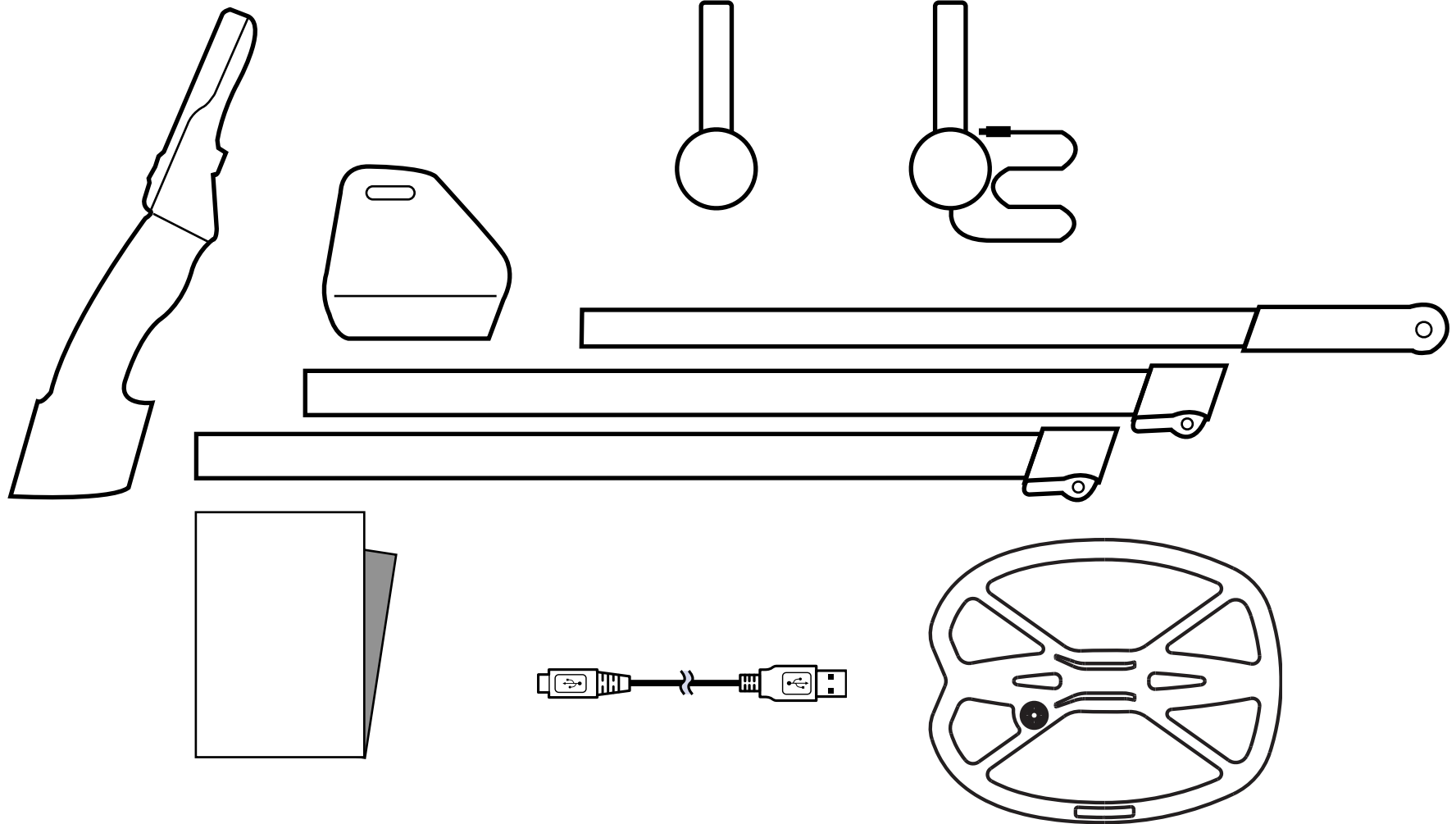

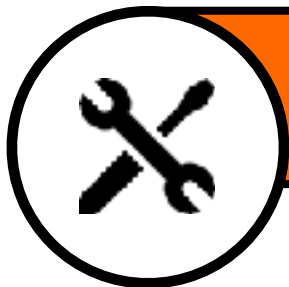

ASSEMBLE

QUICK START

For the first time using. You need a philip screw driver to assemble the unit. Follow the steps illustrated and set a comfortable distance of the handle and tight the screws.

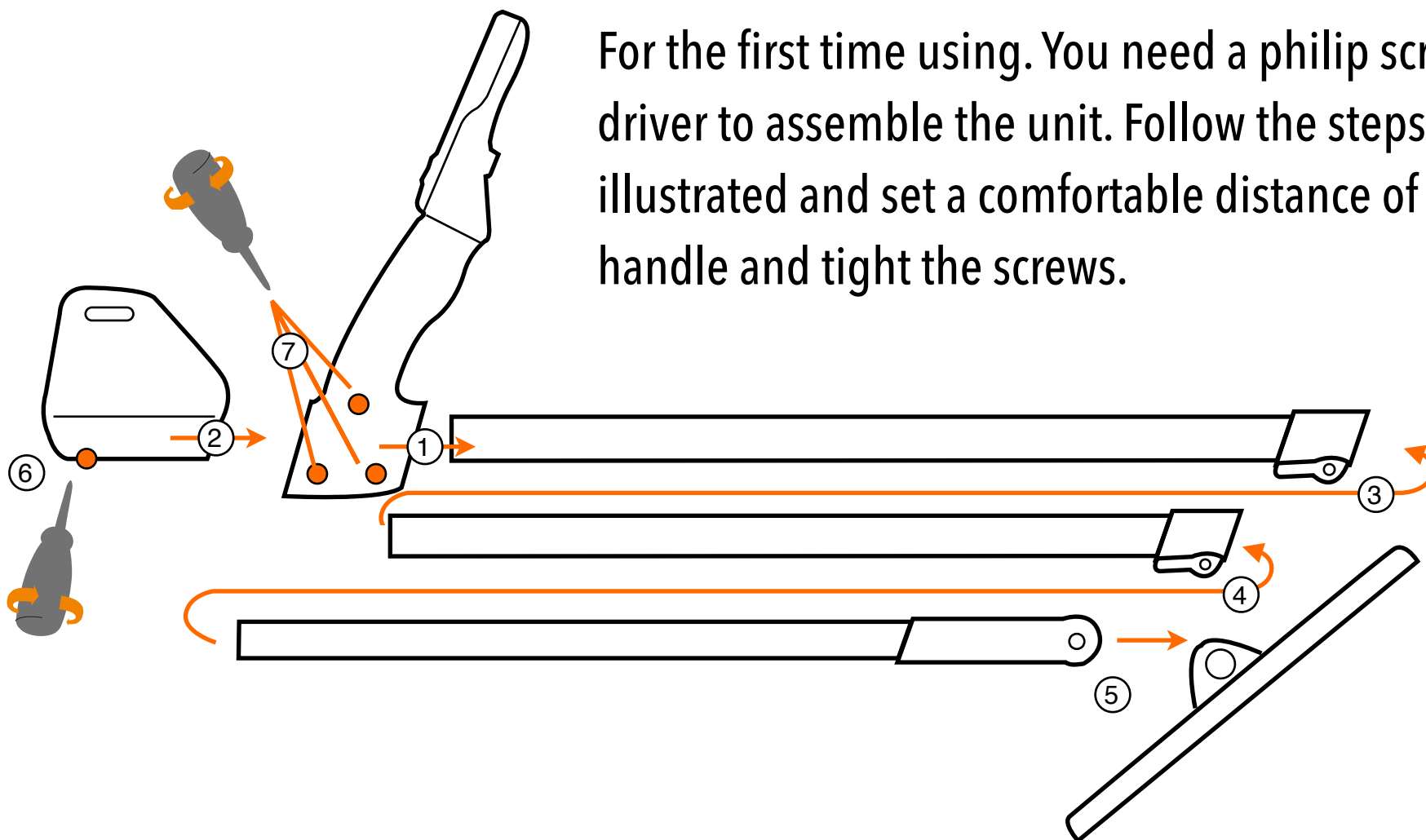



POWER ON/OFF

QUICK START

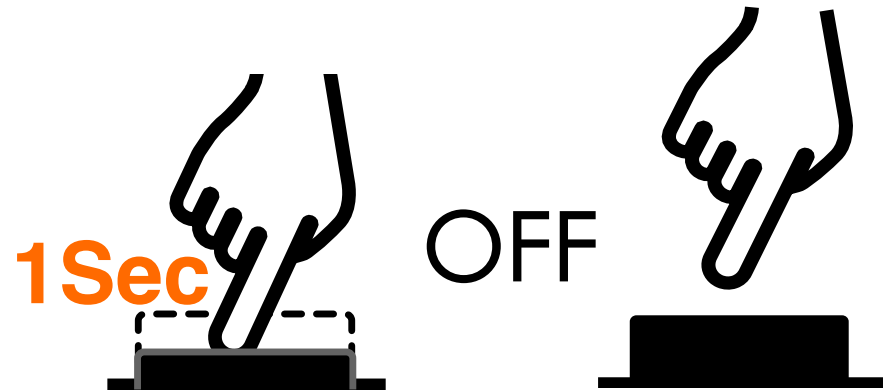
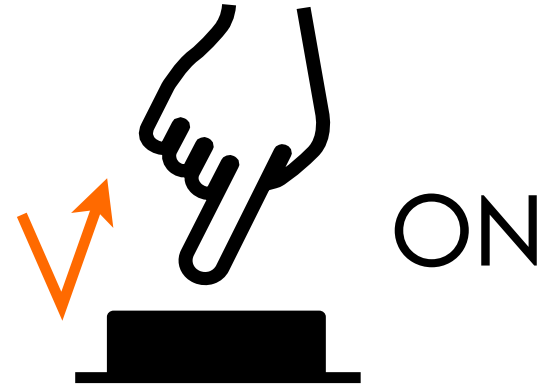

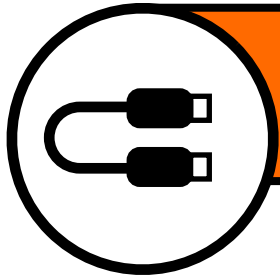

HEADPHONES/CHARGE

QUICK START

WIRE HEADPHONES

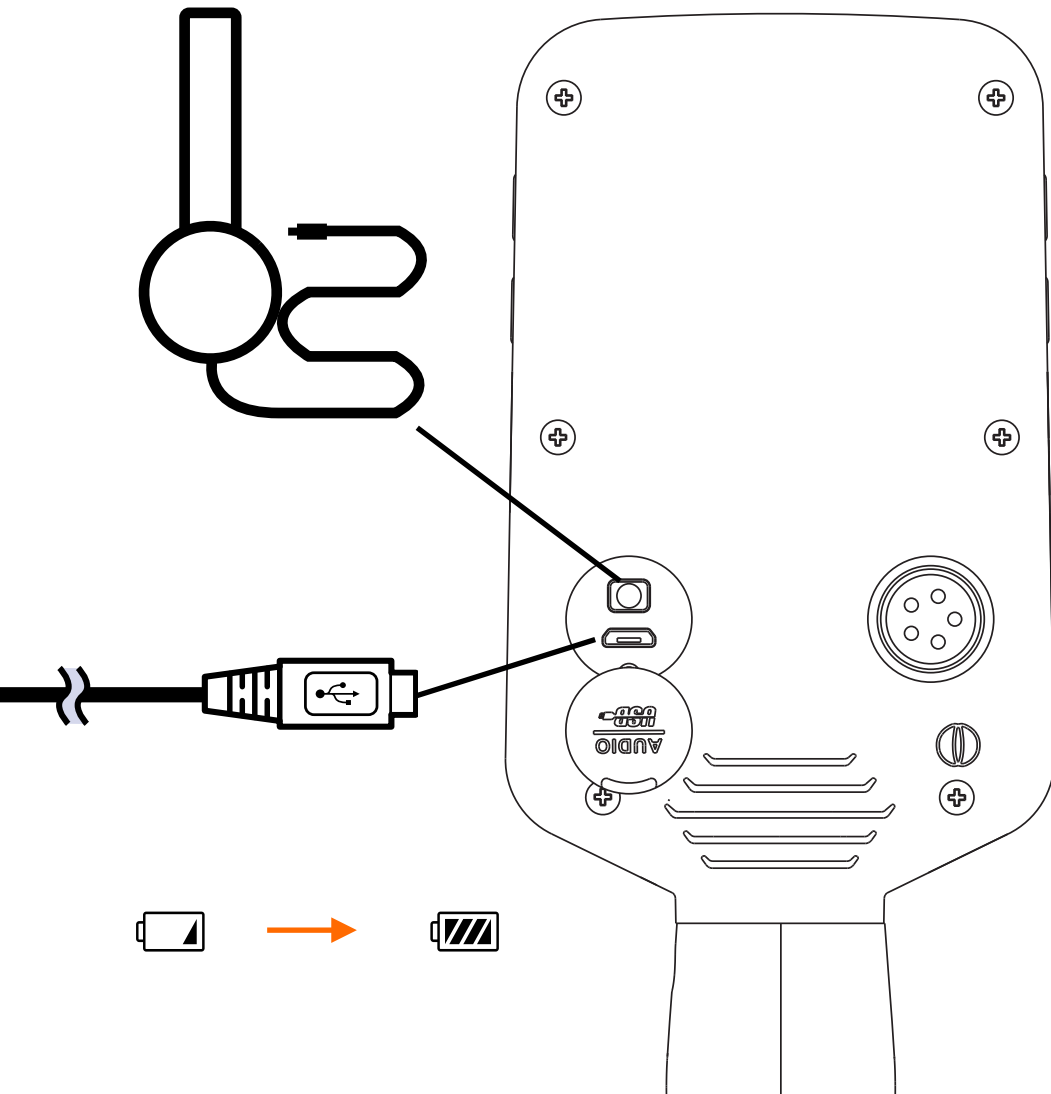

WIRELESS HEADPHONES

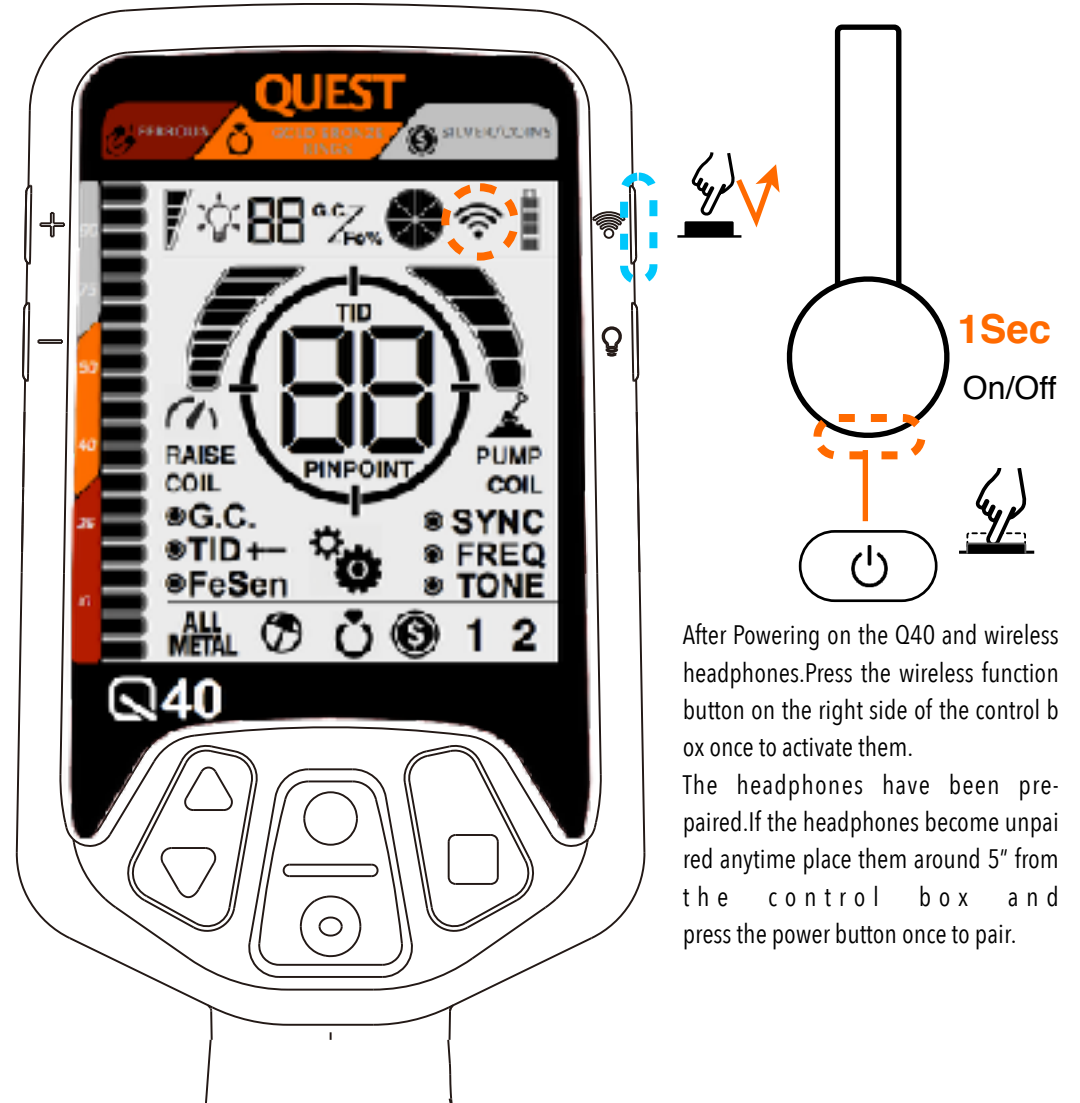

After Powering on the Q40 and wireless headphones. Press the wireless function button on the right side of the control box once to activate them.

The headphones have been prepared. If the headphones become unpaired anytime place them around 5" from the control box and press the power button once to pair.



SPEAKER VOLUME

QUICK START

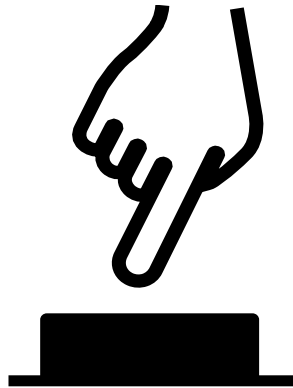

VOLUME + - 1

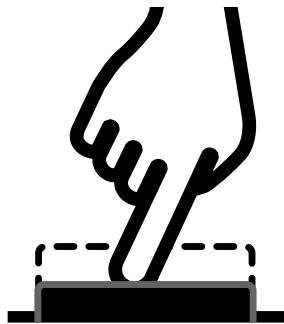

4Sec



MUTE / MAX VOLUME

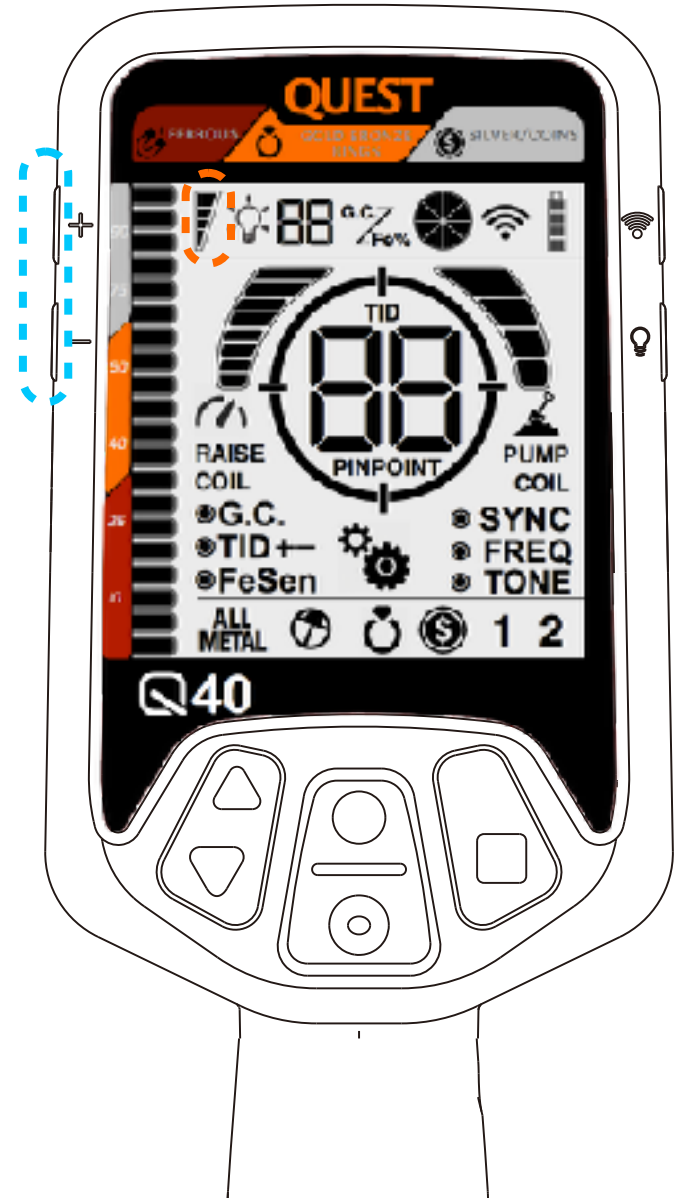



QUICK START

SENSITIVITY

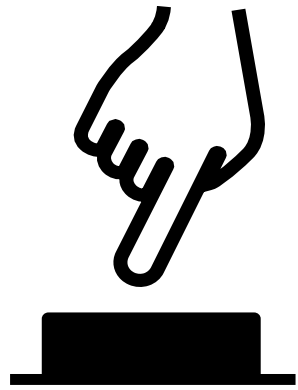

+ / - ONE LEVEL

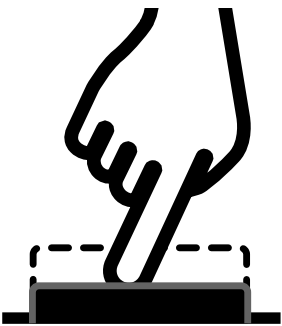

HOLD

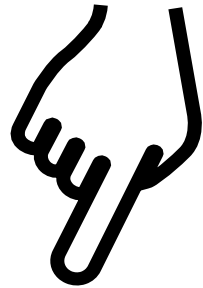

FAST+/- SENSITIVITY



Many things such as Power lines, Electric fences even buildings can cause Electrical Interference & Falsing when your detector is in use and there is no metal under the coil.

Users can reduce the sensitivity by pressing on the downward triangle button directly. Users can increase sensitivity when searching in low Interference Situations. It is always best to maintain sensitivity as high as is possible to achieve best depth.



Level-up

PROGRAM

After powering on the detector to scroll through the various Programs, press and hold the Ground Balance button while at the same time scrolling with the Triangle buttons to arrive at the Programs you want. 1 and 2 are left for customize users own program.

The four preset programs available are:

- Coin Mode. Very stable, medium recovery speed, target for ancient or modern coins TID range 40 - 99
- Jewelry Mode. Very sensitive, high recovery speed, target at Gold rings, Jewelry items. TID range 20 - 99
- All Metal Mode. High recovery speed, ZERO discrimination, good for gold prospecting. TID 0~99
- Beach Mode. Normal sensitivity, low recovery speed, strong saltwater immunity. TID range 20 - 99





PINPOINTING

Level-up

By pressing on the PINPOINT button (the round button with cross sign), the detector will enter a non-motion mode and alarm to target without moving the coil. Users can use this function to pinpoint target with cross action as illustrated.

We strongly recommend to select the Xpointer for further assistance during digging to save the time.

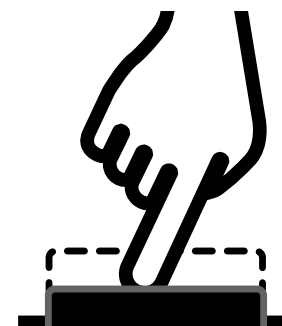

HOLD



GROUND BALANCING

Level-up

The Q40 comes with Ground Balancing (GB) function. We recommend GB every time you change the detecting area. Make sure you have no metal targets under the coil while GB.

Press and hold the square button while pumping the coil 6" (15cm) height to 1" above the ground. While pumping the coil the ground condition will indicate two numbers, when these settle down and are stable GB is complete. The ground mineralization condition is indicated by the round bar with FE%. The GC with two digits indicate the ground cancelling level. If it is not possible to GB on highly mineralized land you can use the GC function in the menu to set it manually.

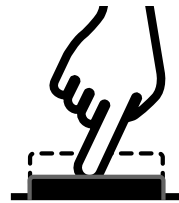
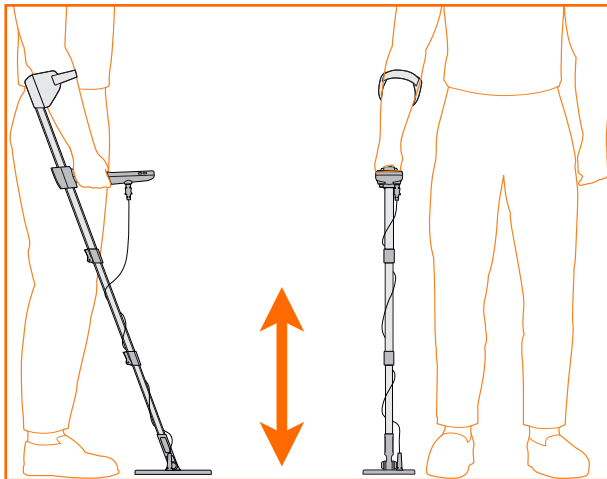

HOLD&PUMP

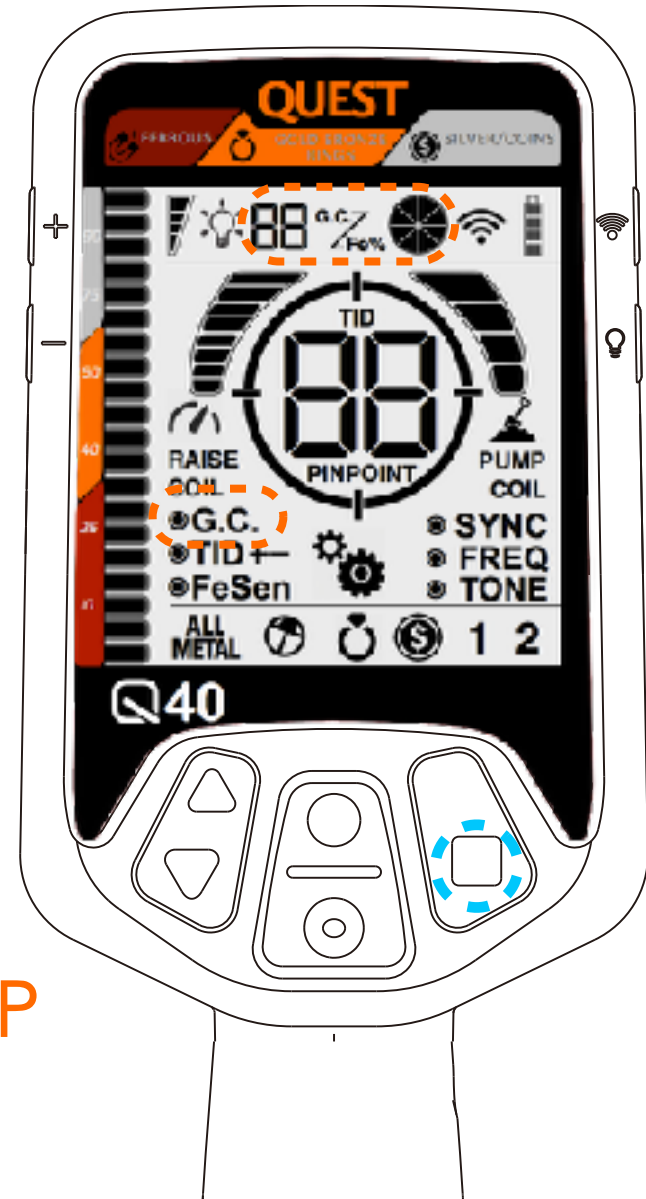



DISCRIMINATION

Level-up

Metal Detectors calculate the metal I.D. through the conductivity of the metal. Higher conductive metals such as silver show higher digit on the screen. Lower conductive such as Iron show lower on the scale usually under 25.

Users can select or deselect some metal I.D.s to discriminate out undesired metal objects.

After powering on click on the M button once and the bar under the digit gauge will flash. Use the Triangle buttons to scroll through and select bars that you wish to discriminate out. Once selected press M to select / deselect to save. Once you have finished press Pinpoint button to return to a working condition.





Level-up

OTHERS

FESEN	FESEN. In Trashy areas some good signals may be muted together by an Iron signal. Users can turn the FESEN function on to have more chance to hear the good signals. It may cause more noise when FESEN has been activated.
G.C.	Ground Canceling Level. After G.B. process the digit will change automatically according to the FE%. You can use this option to set manually.
SYNC	Left for future version products
FREQ.	Users can shift frequencies by this option when detecting with many users or high interference places.
tone	Users can select different TONES by their own preference and different detecting conditions.

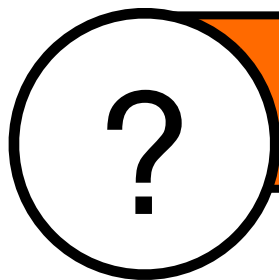

TROUBLE SHOOTING

NOT POWER ON	No power, please recharge. Or contact with your dealer
NO ALARM	Coil not connect to the control box
VERY NOISY	Please find another place with less interference
NO SOUND	Make sure the Volume is not ZERO level
FALSING WHEN SEARCHING IN GRASS	Please confirm the coil cable is not broken

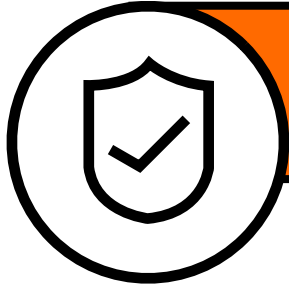

PRODUCTS CARE

NOTICE! Do not twist the coil tail and connector to avoid wire damage.

NOTICE! Do not store the device where prolonged exposure to extreme temperatures can occur to avoid device damage.

NOTICE! Never use a hard or sharp object to operate the touch pad, or damage may result.

NOTICE! Avoid chemical cleaners, solvents, and insect repellents that can damage plastic components and finishes.

NOTICE! Secure the weather cap tightly to prevent damage to the USB port.

NOTICE! Even small amounts of sweat or moisture can cause corrosion of the electrical contacts when connected to a charger.

Clean the detector

- Wipe the device using a cloth dampened with a mild detergent solution.
- Wipe it dry. After cleaning, allow the device to dry completely.
- Use a soft, clean, lint-free cloth. If necessary, lightly dampen the cloth with water.
- If using a dampened cloth, turn off the device and disconnect the device from power.
- Gently wipe the screen with the cloth.
- It can withstand heavy rain. Submersion in water can cause damage to the device.

REGISTER YOUR QUEST

To register the Quest, please go to our website : www.QuestMetalDetectors.com click support, and register products to active your two year warranty. If you have difficulty to register online please contact with your dealer to finish the process. Or, mail this part to following address:

Quest Metal Detectors
Dist. by Deteknix Inc.
California, U.S.A.

Email: info@deteknix.com Website: www.deteknix.com

YOUR VOICE

PLEASE TAKE A FEW MOMENTS TO ANSWER OUR QUESTIONS. THEY WILL HELP US DEVELOP NEW PRODUCTS FOR THE FUTURE.

1 Why did you decide to buy a Deteknix detector?

- Detection performance
- New technology / Features.
- Style / Design
- Ergonomic / Weight
- Recommendation
- Promotion

2 Your age group?

- 18~25
- 26~36
- 37~55
- 56+

Date Of Purchase

MM / DD / YY

Serial Number

[Empty text box for Serial Number]

Title

[Empty text box for Title]

Surname

[Empty text box for Surname]

First Name

[Empty text box for First Name]

Address

[Empty grid for Address]

Zip Code

[Empty text box for Zip Code]

Email

[Empty text box for Email]

Telephone

[Empty text box for Telephone]

We'd like to tell you about new Quest products and services or get your opinion about your purchase. If you'd prefer us NOT to keep in touch, please tick this box.

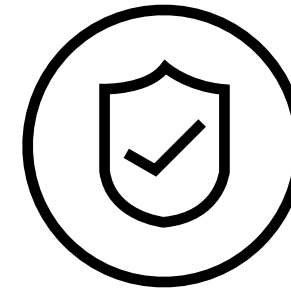

WARRANTY

The Quest metal detectors is warranted against defects in materials and workmanship under normal use for TWO years from the date of purchase to the original owner.

This warranty does not cover:

- No registration on our official website in 5 days from purchase. Or call your dealer for registration assistance.
- Breakage of coil cable or connector.
- Breakage caused by falls, impacts or accidental damage.
- Water flood into control console.
- Damage caused by abnormal use or resulting form noncompliance in the instructions.
- Leakage of battery caused by non compatible charger cable.
- Parts subject to normal wear and tear like : headphone ear pads, cases etc (These parts must be replaced in case of wear and tear, in such a way that no damage will be caused to the device).
- Damage due to neglect, accidental damage, or misuse of this product is not covered under this warranty. Decisions regarding abuse or misuse of the detector are made solely at the discretion of the manufacturer.
- Proof of Purchase is required to make a claim under this warranty.
- Liability under this Warranty is limited to replacing or repairing, at our option, the metal detector returned, shipping cost pre-paid to Quest Products. Shipping cost to Quest Products is the responsibility of the consumer.
- To return your detector for service, please first contact Quest Care for a Return Authorization Number (RAN). Reference the RAN on your package and return the detector within 15 days of calling to(United States customers only)